

# ELLIS

Holding Power

## DATA SHEET

### VULCAN+ TWIST FOOT (QUAD)

- BASE FIXING KIT DESIGNED FOR FAST INSTALL ON 41X41 AND 41X21 UNISTRUT CHANNEL/LADDER
- CLEAT COMES WITH ALL FIXINGS IN PLACE READY FOR INSTALL, NO EXTRA FIXINGS ARE REQUIRED ON SITE
- FIXING KIT CAN BE SUPPLIED IN A4 STAINLESS STEEL, GALVANISED STEEL OR ZINC PLATED STEEL
- SHORT CIRCUIT AND MECHANICALLY TESTED TO IEC 61914 - REFER TO VRQ+ DATA SHEET



VRQ+ TWIST FOOT OPTIONS

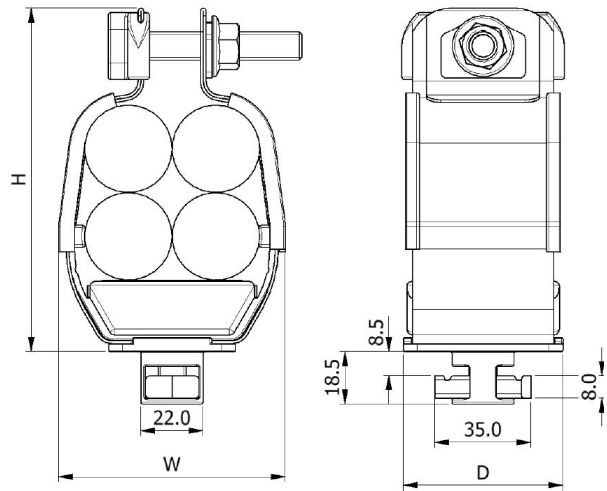

SINGLE FIX TWIST FOOT: VRQ+00 TO VRQ+08

PART NO.	CABLE RANGE QUAD		DIMENSIONS (mm)			WEIGHT (g)
	MIN $\phi$ (mm)	MAX $\phi$ (mm)	W	H	D	
VRQ+00CTFM10-X	10	13	63	96	54	337
VRQ+00BTFM10-X	13	18	67	100	54	330
VRQ+00ATFM10-X	18	20	70	109	54	341
VRQ+00TFM10-X	19	25	74	116	54	367
VRQ+01TFM10-X	23	25	68	113	54	334
VRQ+02TFM10-X	26	27	70	116	54	336
VRQ+03TFM10-X	28	31	78	131	54	368
VRQ+03ATFM10-X	31	35	90	141	54	376
VRQ+04TFM10-X	35	42	103	151	54	428
VRQ+05TFM10-X	43	47	120	168	54	502
VRQ+06TFM10-X	48	50	121	173	54	517
VRQ+07TFM10-X	51	57	140	193	54	573
VRQ+08TFM10-X	58	63	150	203	54	591
VRQ+09TFM10-X	64	70	170	221	54	631

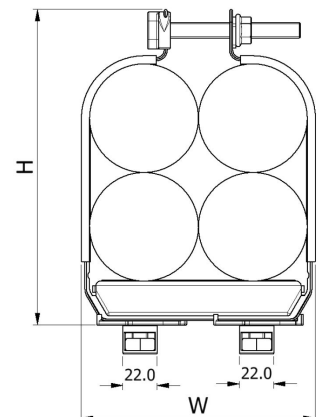

TWIN FIX TWIST FOOT: VRQ+09

'X' DENOTES FIXING MATERIAL,  
OPTIONS ARE AS FOLLOWS:  
4 = A4 STAINLESS STEEL  
G = GALVANISED STEEL  
Z = ZINC PLATED STEEL

E.G A VRQ+04 WITH STAINLESS  
STEEL TWIST FOOT FIXINGS  
BECOMES: VRQ+04TFM10-4



### INSTALLATION OVERVIEW

SINGLE FIX TWIST FOOT: VRTQ+00 TO VRQ+08

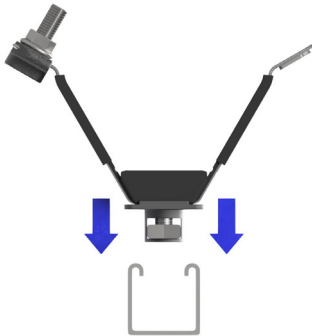

1) Lower the cleat through the gap in the channel.

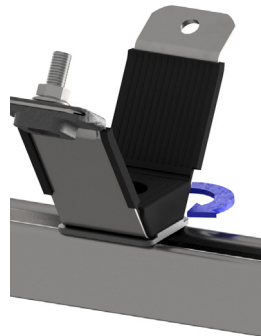

2) Once lowered twist the cleat 90°.



3) Tighten the M10 bolt in the base of the cleat.



4) As the bolt is tightened the channel nut will move up the twist foot base and grip onto the channel.



5) The cleat is now securely fastened to the structure and is ready to accept the cables.

TWIN FIX TWIST FOOT: VRQ+09



1) Lower the cleat through the gap in the channel.



2) Rotate both twist foot bases through 90° into the locking position.



3) Tighten both bolts in the base of the cleat to the same torque value.



4) As the bolts are tightened the channel nuts will move up the twist foot base and grip onto the channel.



5) The cleat is now securely fastened to the structure and is ready to accept the cables.

This data sheet is subject to change without notice. The information provided has been generated in laboratory conditions, as such results in use may vary.