

### MULTI-FIX PEGASUS CABLE HANGERS

- HANGER SYSTEM DESIGNED TO BE AFFIXED TO POSTS OR WALLS
- LOW PROFILE DESIGN ALLOWS HANGER TO BE SLID IN BEHIND EXISTING CABLES WITHOUT DISTURBING EXISTING HANGERS
- POLYMER MATERIAL WILL NOT RUST OR CORRODE
- INSULATING HANGER WITH EXCELLENT DIELECTRIC PROPERTIES, NO EARTH BONDING OR GROUNDING REQUIRED
- ADJUSTABLE HANGER POSITION IN 20MM INCREMENTS
- AVAILABLE WITH SHORT (120MM) OR LONG HANGERS (150MM)
- AVAILABLE IN LUL 1-085 LSF MATERIAL FOR INDOOR APPLICATIONS OR UV STABILISED MATERIAL FOR EXTERNAL APPLICATIONS
- SLIDE IN HANGERS AND KEEPERS ALLOW RAPID INSTALLATION
- SWL 20KG PER HANGER

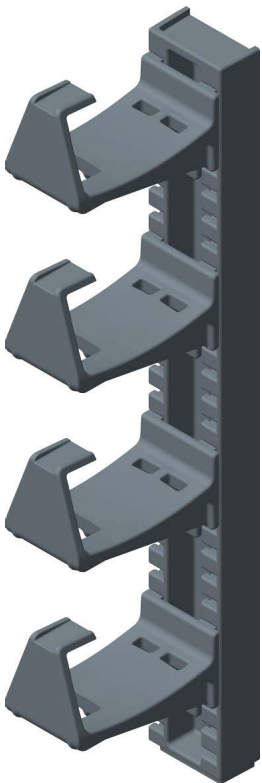

120MM HANGER

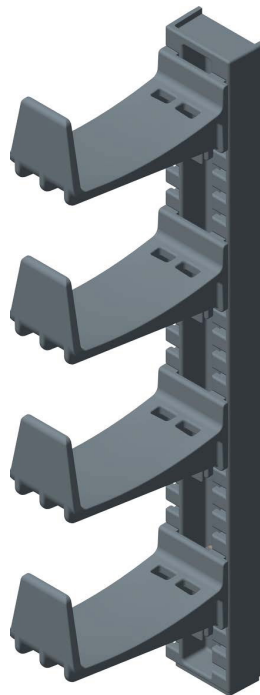

150MM HANGER

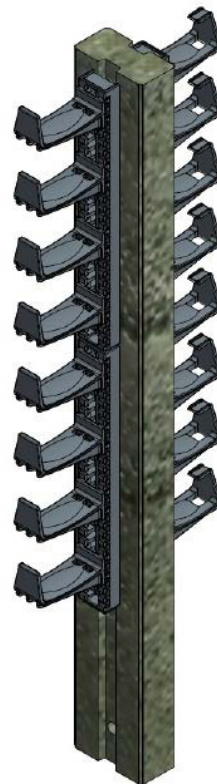

POST HANGER INSTALLATION

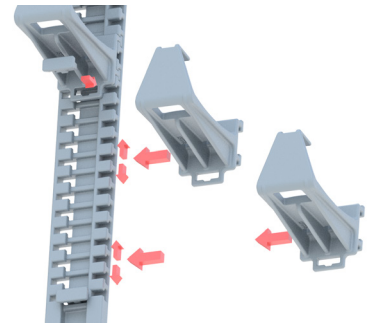

The hangers slide into the backplate and are held in position by a removable keeper. The design allows for fine adjustment of the hanger position to suit the location of the installed cable.

### MULTI-FIX PEGASUS CABLE HANGERS

**TWO HANGER LENGTHS AVAILABLE:**

**(120MM & 150MM)**

**TWO MATERIAL OPTIONS**

**INDOOR - LUL 1-085**

**AND OUTDOOR - UV RESISTANT**

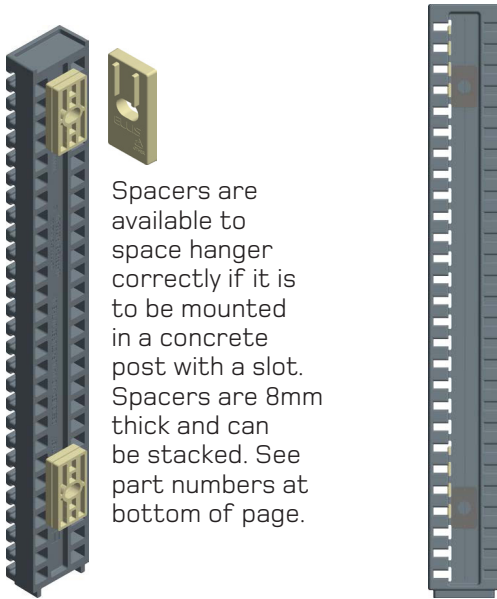

Spacers are available to space hanger correctly if it is to be mounted in a concrete post with a slot. Spacers are 8mm thick and can be stacked. See part numbers at bottom of page.

Backplates are supplied undrilled and are required to be drilled on assembly dependant on fixing. Stainless Steel washers are required to spread the load over the backplate. Fixings are M12 and minimum two are required.

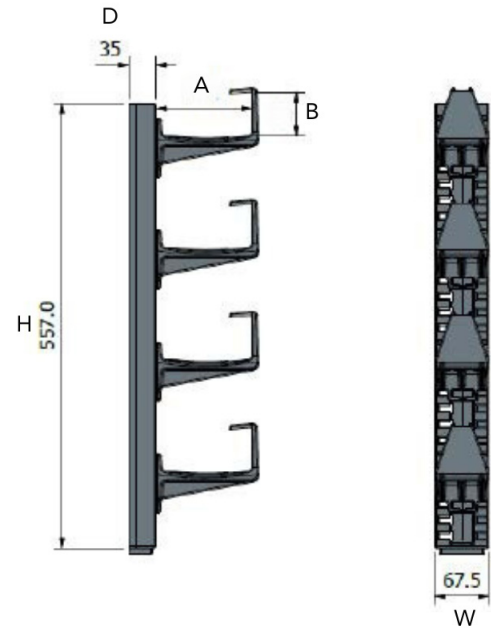

PART NO.	DESCRIPTION	DIMENSIONS (mm)						MATERIAL	WEIGHT (g)
		H	W	D	A	B			
PFPG-BKPL565	MULTI-FIX BACKPLATE	557	67.5	35	-	-	LUL 1-085	790	
PFPG-BKPL565-UV	MULTI-FIX BACKPLATE (UV)	557	67.5	35	-	-	UV RESISTANT	790	
PFPG-SPC01	BACKPLATE SPACER	-	-	-	-	-	LUL 1-085	19	
PFPG-SPC01-UV	BACKPLATE SPACER (UV)	-	-	-	-	-	UV RESISTANT	19	
OF-PFPG-WASHER-01-4	BACKPLATE WASHER	-	-	-	-	-	STAINLESS STEEL	-	
SFPG-CC01	CC01 HANGER (120mm) & KEEPER	-	-	-	120	54.6	LUL 1-085	260	
SFPG-CC01-UV	CC01 HANGER (120mm) & KEEPER (UV)	-	-	-	120	54.6	UV RESISTANT	230	
SFPG-CC02	CC02 HANGER (150mm) & KEEPER	-	-	-	143	60	LUL 1-085	295	
SFPG-CC02-UV	CC02 HANGER (150mm) & KEEPER (UV)	-	-	-	143	60	UV RESISTANT	250	

Dimensions are provided with a tolerance, refer to detailed drawings for details.

This data sheet is subject to change without notice. The information provided has been generated in laboratory conditions, as such results in use may vary.