

- USED TO SPACE STRANDS PRIOR TO SPLAYING ENDS
- MULTIPLE SIZE OPTIONS AVAILABLE
- CUSTOM PLATES CAN BE MANUFACTURED
- DESIGNED AND MANUFACTURED IN THE UK

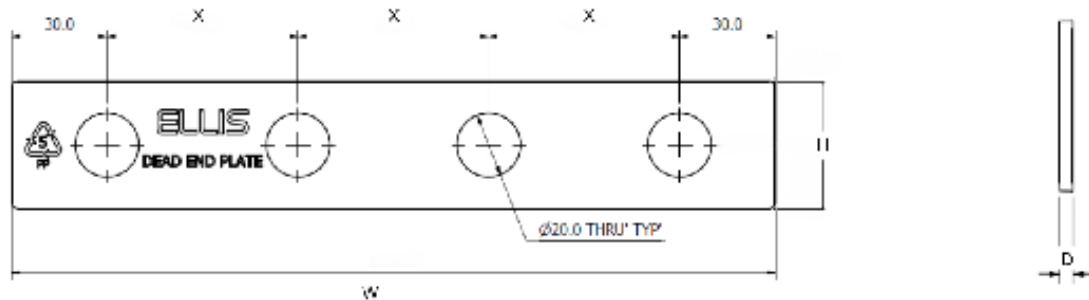

PART NO.	NUMBER OF STRANDS	DIMENSIONS				MATERIAL
		X (mm)	H (mm)	W (mm)	D (mm)	
DEP-2S	2	60	40	120	3	POLYPROPYLENE
DEP-2S-80X	2	80	40	140	3	ABS
DEP-3S	3	60	40	180	3	POLYPROPYLENE
DEP-3S-80X	3	80	40	220	3	ABS
DEP-4S	4	60	40	240	3	POLYPROPYLENE
DEP-4S-80	4	80	40	300	3	POLYPROPYLENE
DEP-4S-80X	4	80	40	240	3	ABS
DEP-5S	5	60	40	300	3	POLYPROPYLENE
DEP-5S-85M	5	85	65	400	2	MILD STEEL
DEP-9SM	3 x 3	50	300	300	2	MILD STEEL